

GRILL DOME KAMADOS

Making Quality Kamados since 1989.



Instruction Guide

GRILL DOME

4220 Steve Reynolds Blvd. Suite 11

Norcross, GA 30093

Ph. 678-924-0545 Fax. 678-924-0565

E-mail: grilldome@grilldome.com

<http://www.grilldome.com>

Table of Contents

Table of Contents.....	2
Internal Construction	3
Dos & Don'ts.....	4
Unpacking.....	5
Starting your Grill Dome	7
Shutting Down your Grill Dome.....	10
Maintaining your Grill Dome	11
Suggested Temperatures and Times for Grilling & Roasting.....	12
Lifetime Warranty.....	14

Internal Construction

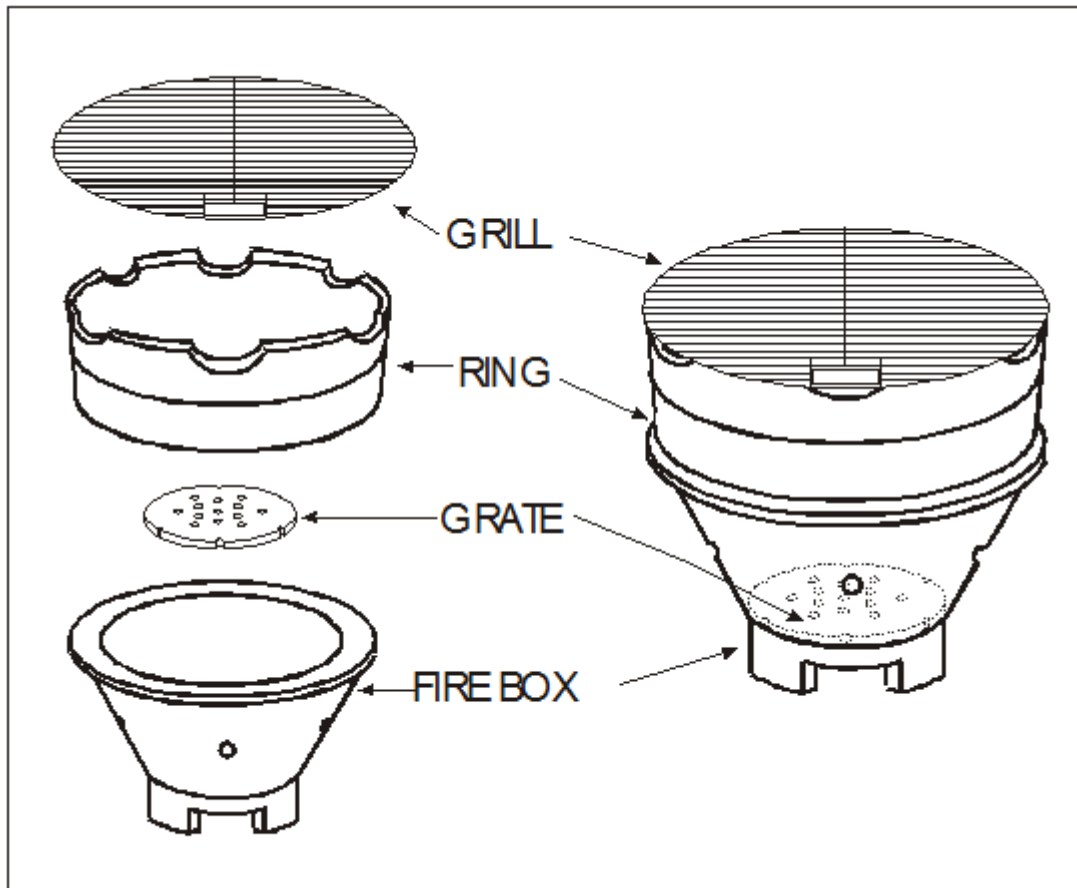

Dos & Don'ts

1. Please check all the bolts on the metal bands for tightness. Inspect these periodically and tighten the bolts if necessary.
2. Do not remove the white or grey gasket from the rims of the Grill Dome. Its purpose is to help seal the cooker, provide cushion and muffle the sound that would be generated when the lid is closed.
3. Keep the Grill Dome from coming in direct contact with the wooden surface it is going to sit on by setting it up on the three feet it comes with. You can also use bricks, ceramic, concrete or stone tile. Even in the case of setting it up on a concrete, brick or stone patio you should set it up on the three feet to avoid low spots where water can puddle. You do not need to use the feet if you are setting it up on metal stand, cart or a table.
4. Never use lighter fluid.
5. Do not use water to extinguish the charcoal. Just close the dome top damper and bottom sliding damper to extinguish the charcoal.
6. Do not remove ashes while the Grill Dome is being lit or is in use. To remove ashes, open the bottom sliding door and use the ash tool/poker to pull the ashes out in to your container or on to a piece of aluminum foil. You can dispose the ashes off either by making a packet in the aluminum foil or by simply putting them in you plant beds. Ashes need to be removed only periodically.
7. Charcoal grate should be put with the small hole on the top and big hole towards the bottom.
8. While starting or cooking do not walk away from the Grill Dome with dampers wide open.
9. Before starting always rake the left over charcoal with the Ash Tool. This helps a great deal in starting the Grill Dome faster by improving the air flow through the charcoal. The ashes and tiny pieces of charcoal that had built up above the grate fall down in to the bottom ash compartment of the Grill Dome. The ashes are removed only periodically.
10. Always start the old charcoal first and then add make up charcoal if needed. The lesser the charcoal the faster the Grill Dome will get started.
11. While starting, the lid should be closed right after you light the fire starters or you insert the electric charcoal lighter (close the lid on the electric cord). You should have the top and bottom dampers wide open to create the draft.
12. For foods that have lots of fat, use a pan to catch the drippings.
13. If there are lots of dripping falling on to the fire do not keep the lid open too long. These drippings can sometimes catch fire because of availability of lots of air (oxygen) when the lid is open.
14. If the dripping catch fire close the lid and the bottom damper immediately. Do not close the top damper. Shut the top damper so that it is only about 1/2 inch open after about 5 minutes.
15. Do not cook with the lid open. If you are using chips or there are lots of drippings keep it open for as little as possible as they can catch fire.
16. When shutting down, DO NOT close both dampers at the same time. Close the bottom damper first and leave the top damper slightly open. After 15 minutes, once the temperature has come down, close both dampers.
17. For safety and other considerations do not operate the Grill Dome over 700 ° F. Grill Dome can withstand temperatures substantially higher than 700 ° F.

Unpacking

1. Cut the white strapping with a scissor or knife and remove the outer packing of the Grill Dome.

This includes the -

- Clear plastic cover
 - Top cardboard packing
 - Middle card board strip
 - Bottom card board
 - Styrofoam or rubber packing
2. Cut the twine or tie on each side of the cooker that ties the big bolts.
 3. Do not remove the white or grey cloth gaskets around the lip of the base and the lid.
 4. Open and lock the lid to remove packing inside the grill.
 - If you have a scissor hinge model, remove the cloth which is wrapped around the side hinges. Open the lid by lifting from the handle. Lock the lid in to position by pulling the extended thumb arms of the side hinges towards you one at a time.
 - If you have the Auto Hinge Model simply open the lid gently to the final position.
 5. Remove the internal packaging
 - Remove the card board packaging inside.
 - Remove the porcelain coated cooking grill.
 - Take out the ceramic top, ceramic charcoal gate and the 3 ceramic shoes or feet.
 - Remove the top circular ceramic ring. Remove any rubber or wood packaging you may find around the Firebox.
 - Remove the Firebox. Remove any packaging below the Firebox.
 - Remove any other small packing materials from the inside of the Grill Dome.
 6. Place the grill in its resting place without the internal components –
 - Insert the ceramic shoes or feet between the bottom of the cooker and the surface it is sitting on by slight tilting or by lifting the cooker (it takes two people).
 - Spread the feet equally around the bottom surface of the cooker. You do not need to use the feet or shoes if the Grill Dome is going to sit in a metal table, dome mobile, wagon wheel or other metal carts.
 7. Put all internal parts back into the Grill Dome once the cooker is set in place.
 - Put the firebox in first. Make sure the mouth of the firebox is facing the bottom damper door to allow for proper ash removal.
 - If you have a SuperDome, place the solid ceramic circular disk into the middle of the firebox.
 - Put the ceramic charcoal grate in the firebox as shown in the inside construction diagram. **It has tapered holes and goes only one way.** The rounded edge goes towards the bottom and the wider sized holes go towards the top.

- Put the circular ceramic ring in.
- Put the porcelain cooking grill back in.

8. Close the lid

- If you have the scissor hinge, to close the lid slightly lift the lid by lifting from the handle and then push the extended thumb arms of the side hinges away from you one at a time. Lower the lid gently into closed position.
- If you have the auto hinge close the lid gently.
- Do not jerk open the lid or drop it while closing.

Starting your Grill Dome

The Grill Dome is ready to cook as soon as you have it unpacked and set up on the three shoes, wagon, table or any other thing up from the floor.

We recommend using lump charcoal as fuel. High quality charcoal briquettes are an acceptable alternative. Even wood chunks can be used either by themselves or mixed with the charcoal. Wood chunks will produce more smoke and should be left to burn for sometime before putting the food on. Too much smoke can make your foods taste bitter. This does not apply to when few wood chunks or smoking chips are used for smoking.

Step 1 Open the lid of the Grill Dome and lock it into place if yours is the scissor hinge model. If you have the auto hinge model it will stay open by itself when fully opened.

Step 2 Remove the porcelain cooking grill.

Step 3 Add Charcoal in the fire box if it is your first cook. The charcoal is mounded with the center being high and the sides lower. The charcoal level at the center of the fire box should be about one to two inches above the top of the holes in its sides and it should come down to the bottom of the holes at the sides (circumference).

If you are restarting your grill dome after having used it before then do not add more charcoal at this time. Stir the left over charcoal with your Ash Tool or a long handled spoon etc. to make the ashes and small pieces of charcoal fall into the bottom compartment. It is very important to do the stirring so that the ashes and small pieces of charcoal do not build up above the ceramic charcoal grate. They can substantially curtail the air flow through the charcoal. This in turn will slow down the starting of charcoal and will also make it difficult to achieve high temperatures such as 500 degrees.

Step4 Open fully the bottom draft door and the top damper or slide metal top of your Grill Dome.

Step 5 To start the charcoal various methods can be used. Your job is to get a few pieces of charcoal started, the Grill Dome takes over from there because of its in built chimney effect (draft system). Using the chimney starters is not recommended.

Do not use lighter fluid.

To start the charcoal you can use news paper. Make two or three balls of loosely crumpled paper. Put them in the center on top of the charcoal. Move two to four pieces of charcoal on top of the news paper balls. Light the news paper balls with a long matches or butane lighter. Put the cooking grill back in and close the lid right away while leaving both the bottom draft door and top damper fully open. This should start the fire inside your Grill dome.

Note: a few pieces of kindling are required while using briquettes.

An electric charcoal lighter is more efficient. Put the heating element on top of the charcoal in the center. Move a few pieces of charcoal on top of the element. Plug the electric cord into an outlet. Close the lid on the electric cord and leave both the bottom draft door and top damper fully open. Follow electric charcoal lighter's manufacturer's directions. Normally you should unplug and take out the electric charcoal lighter with in 8 minutes. After taking out the electric starter put the cooking grill back in and close the lid

You can also use fire starters, the ones that are used for lighting camp fires, fire places or other similar things. They work very well as compared to the news paper. The procedure is the same as described for starting with the news paper. You need to use only one to two squares or sticks of fire starters.

- Step 6 Watch the temperature on the external gauge rise (in 6 to 10 minutes). When the temperatures rises to above 250 degrees Fahrenheit you can walk away from the Grill Dome after closing the dampers to the following positions : top damper or slide metal top about 1/2 inch open, and the bottom damper two fingers open. While you are gone the Grill Dome will stabilize in the range of 300 to 350 degree range. Do not walk away from the Grill Dome while starting as temperatures can get dangerously hot in a short time with a full load of charcoal and both the draft door and top damper wide open. In case you have to walk away close the dampers partially as described earlier.

To adjust or set the temperatures to the desired cooking temperature, adjust the bottom draft door and leave the top damper at 1/2 inch open. To increase the temperature, open the bottom draft door more and to reduce the temperature close it a little.

As a rule of thumb, 1/4 inch opening or closing the damper will make a difference of about 40 degrees Fahrenheit.

Also remember the bottom draft door controls the temperature and glow of charcoal (hot, medium, low) while the top damper controls the temperature and smoke flavor. So, if you open the top damper more, temperature will increase and smoke flavor will decrease. For someone who does not like the smoke flavor, cooking should be done with the top damper wide open while controlling the temperature with the bottom draft door.

- Step 7 After you have set up the dampers and the temperature has gone about 50 degrees over the desired cooking temperature, open the lid and put the food on the grill. Close the lid and wait for temperature to stabilize. The temperature will drop but then will start going up again. A difference of up to about 20 degrees Fahrenheit either way will not make much difference except in the cooking time. In case you need to adjust the temperature adjust the dampers as described earlier.

With a little practice you will easily be able to maintain the desired temperatures for the duration of the cooking.

Step 8 To extinguish the fire close the lid and the bottom draft door. Leave the top damper open like it is for 5 minutes before you fully close it. Leaving the top damper open like this will help keep your grill drier and safe from excessive accumulations.

Shutting Down your Grill Dome

Once you have completed your cook on the Grill Dome and are ready to shut down the grill, use the following steps.

- 1) Close the bottom damper completely
- 2) Leave the top damper a quarter open for 15 min.
- 3) Once the air temperature within the grill has reached below 250 degrees, you can close the top damper completely.

Maintaining your Grill Dome

The Grill Dome requires very little maintenance as compared to other style grills. Here are a few tips and cautions on maintaining your Grill Dome.

- **Ash Removal** - Ashes can be removed every 3 to 4 uses.
- **Porcelain Grill** - Use a light brush to clean the porcelain grill. The grill is dishwasher safe as well.
- **Covers** – We recommend protecting your Grill Dome with a vinyl cover as it will protect your grill from the natural elements and reduce any chances water may get inside your grill.
 - *NOTE – *if you live in an area where there is **heavy snow***, it is important to ensure your Grill Dome is not sitting in accumulated snow. As the snow melts, water may get into your grill through capillary action.

Suggested Temperatures and Times for Grilling & Roasting

Type of Meat	Type of Portions	Weight/ Thickness	Temp. (in F)	Approx. Rare	Approx. Medium
Beef	Hamburger – turn once	3/4”	500	8 Min.	10 Min.
		1/2”	500	6 Min.	8 Min.
	Rib Eye Steak –turn once	1 1/4”	550	10 Min.	12 Min.
		3/4”	600	8 Min.	10 Min.
	T- Bone Steak – turn Once	1/2”	600	7 Min.	9 Min.
		3/4”	600	8 Min.	10 Min.
		3/4”	500	11 Min.	13 Min.
	Porterhouse Steak– turn once	1”	550	10 Min.	12 Min.
	Roast (cook indirect)	5-6 lbs.	400	45 Min.	1 Hr.
		turn once 8-15 lbs	350	2 Hrs.	2 Hrs.
Kabobs on Metal skewers – turn 1 time		400	10 min.	12 min.	
Pork	Chops – turn 1 or 3 times	1 1/2”	350		25 Min.
		1”	350		20 Min.
	Chops boneless – turn Once	1 1/2”	350		20 Min.
	Loin Cook indirect-turn once	6 lbs.	350		1 1/2 Hrs.
	Whole Ham- cook indirect-turn once	5 lbs.	350		2 Hrs.
	Canned Ham Cook indirect-turn once	5 lbs.	350		1 1/2 Hrs.
	Sliced Ham – turn 3 times	1 lb.	350		20 Min.
	Ribs – Baby Back - indirect –turn 3 times	2 racks	325		2 Hrs.
	Kabobs on metal skewers –turn 1 time		350		15 Min.
	Chicken	Un-stuffed whole – Indirect and on chicken rack	5 lbs.	375	
			400		50 Min.
Un-stuffed whole – Indirect- turn 1 times		5 lbs.	350		70 Min.
Stuffed whole – indirect – turn 3 times		5 lbs	350		80 Min.
Chicken Breast- turn 1 or 3 times			375		15 Min.
Chicken drumsticks, thighs and leg quarters with skin – turn 3 times			375		30 Min.
Chicken drumsticks, thighs and leg quarters – skinless – turn 3 times		350		24 Min.	

Type of Meat	Type of Portions	Weight/ Thickness	Temp. (in F)	Approx. Rare	Approx. Medium
Turkey	Un-stuffed – indirect and on turkey rack	12 lbs.	375		2 Hrs
	Un-stuffed – indirect – turn 1 time	12 lbs.	375		2Hrs. 15 Min.
	Un-stuffed – indirect – turn 1 time	15 lbs.	350		3 Hrs.
	Un-stuffed – indirect – turn 1 time	25 lbs.	325		5 Hrs.
	Stuffed - indirect – turn 1 time	12 lbs.	375		2Hrs 15 Min.
	Stuffed – indirect – turn 1 time	15 lbs.	350		2 Hrs 30 Min.
	Stuffed – Indirect – turn 1 time	25	325		5 hrs. 30 Min.
	Breast – indirect –turn 1 time	8 lbs.	325		1Hrs. 30 Min.
Fish	Salmon, Halibut Steaks – turn 1 time		400		11 Min.
	Salmon, halibut fillets – skinless –turn 1 time		400		11 Min.
	Salmon, Halibut Fillets with skin –cook with skin side down – do not turn		400		16 Min.
	Trout, Snapper, Pomfret whole with skin- turn 1 time		400		11 Min
Shrimp	On metal skewers – turn 1 time		500		6 Min.
	On grilling wok that has holes		500		6 Min.
Lobster	Tails	8 oz.	400		14 Min.
			500		9 Min.
Lamb	Chops – turn 1 time	¾”	500	9 Min.	11 Min.
		1½”	450	11 min.	14 min.
	Leg with bone – indirect – turn 1 time	4 lbs.	350	1Hr. 30 Min.	2Hr.
	Leg with bone – indirect – turn 1 time	8 lbs.	350	1 Hr 30 Min.	2 Hr.
	Leg boneless – indirect – turn 1 time	4 lbs	325	2 Hrs	2Hr 30 Min
	Kabobs on metal skewers – turn 1 time		400	10 Min.	12 Min.
Duck	Whole – Indirect – turn 1 time	3 to 6 lbs	375		1½ Hrs.
Guinea	Whole – indirect - turn 1 time	3 to 6 lbs.	375		1¼ hrs.
Quail	Whole – turn 1 time	12 Oz.	400		10 min.
Veal	Chops – turn 1 time	¾”	500		12 Min.
Rumake	On metal skewers- turn 1 time		375		10 min.
Potatoes	Baked – in foil				
	Roasted direct				

GRILL DOME KAMADOS

Limited Lifetime Warranty

This Grill Dome carries a limited lifetime warranty to the original purchaser whose name appears on this warranty card and the matching invoice. This warranty covers damage to the ceramic parts due to cooking heat and does not cover any costs related to shipping, mailing, special packaging and postage.

Defective parts will be replaced with new parts after return or receipt of the defective parts at the Grill Dome headquarters. This warranty does not cover damage caused by misuse, improper use, improper maintenance, abuse, neglect, acts of God, alteration and accident.

To activate your warranty you must register your Grill Dome within 30 days of purchase.

Option 1: Register your Grill Dome Online. (1-2 Weeks) *Highly recommended*

Please visit the following address: http://grilldome.com/GD_WWW/Register.aspx

Option 2: Register via mail (6-8 Weeks) (SKIP if you have elected to register online)

If you would like to complete your warranty registration via mail please complete the following form.

First Name		Last Name	
Address 1		Address 2	
City		State	
Zip		Phone	
Email			
Gender	<input type="checkbox"/> Male	<input type="checkbox"/> Female	Date of Birth

Store Name		Date Purchased	
Store Address			
Order Total		Phone	
GD Model		Size	
Color	<input type="checkbox"/> Black <input type="checkbox"/> Red <input type="checkbox"/> Blue <input type="checkbox"/> Copper <input type="checkbox"/> Green		
Size	<input type="checkbox"/> SuperDome <input type="checkbox"/> Large <input type="checkbox"/> Medium <input type="checkbox"/> Small		

A completed version of this form and a copy of the purchase receipt/ invoice must be mailed to the address below within 30 days of the purchase to activate the warranty. Also, the customer must sign this form verifying they have received and read the instruction manual. This form will be mailed back to you after it has been authenticated and signed by an authorized representative of the company. You must possess this duly signed card as a proof of activation. If you do not receive this card within 6-8 weeks of mailing please call us.

I have received and read the instruction manual.

Customer signature _____

The following will be completed by GRILL DOME:

Registration ID _____

Authorized Signature _____

GRILL DOME HQ Address:
4220 Steve Reynolds Blvd. Suite 11
Norcross, GA 30093
Ph. 678-924-0545 Fax. 678-924-0565

GRILL DOME KAMADOS

Limited Lifetime Warranty

This Infinity Series Grill Dome Kamado carries a Lifetime Warranty to the original purchaser whose name appears on the purchase invoice, and who has registered their Warranty with the offices of Grill Dome.

This warranty covers damage to the ceramic parts due to cooking heat.

Warranty does not apply to damage caused by improper assembly, misuse, accidents, commercial use, mechanical alterations, negligence, improper care, natural or accidental disasters. The Grill Dome will not be liable for any transportation charges, packaging costs, or export/import duties, or levied taxes. Except as provided in this CONDITIONS OF WARRANTIES paragraph, repair or replacement of parts in the manner and for the period of time stipulated hereunder shall constitute the fulfillment of all direct and derivative liabilities obligations from the Grill Dome.

1. The Warranty coverage begins on the original date of purchase and proof of date of purchase is required to validate the Warranty.
2. The pouring of liquids on your grill flame will void the Warranty. Starter lighter fluid is not to be used to start the fire inside the Grill Dome.
3. The Warranty SHALL NOT APPLY, nor will the Grill Dome assume responsibility for damages that might result from failure to follow prescribed procedures, or which, in Grill Dome's judgment the unit has been subjected to misuse, neglect or accident
4. The Warranty coverage is not transferable.
5. The Warranty will not be validated if purchased from an unauthorized dealer.

PROCEDURES FOR WARRANTY SERVICE

Contact your nearest Grill Dome Dealer for part replacement under the conditions of the Warranty. Be prepared to furnish the following: a registration/warranty number, purchaser's name, date of purchase, location of purchase, and an accurate description of the problem or the defective parts.

Grill Dome is not responsible for shipping costs.

Failure to complete and return the Warranty Registration Card will invalidate your warranty.